

---

# ***Installation Instructions***

---

**SERIES 238**

## **WINDOWS**

Page 2:	<i>Opening Preparation and Wood Buck Installation</i>
Page 3-4:	<i>Installation Instructions for Series 238 WINDOWS</i>
Page 5:	<b>Figure 1:</b> <i>Buck preparation and frame installation</i>
Page 6:	<b>Figure 2:</b> <i>Fixed window attaching screws</i> <b>Figure 3:</b> <i>Mullion end anchorage detail</i>
Page 7:	<b>Figure 4:</b> <i>Mullion to mullion anchorage detail</i>

**NOTE:** Read instructions completely before attempting any installation.

**PRODUCTS ARE SHIPPED FROM FACTORY IN THE FOLLOWING MANNER**

<b>OPERABLE WINDOWS:</b>	<i>Window pre-assembled at factory. Operator crank shipped separate.</i>
<b>DESIGNER AND FIXED WINDOWS:</b>	<i>Frame and vent attached with screws at factory. Plastic caps for screws shipped separate.</i>

*These instructions are provided as a general guide in the installation of our Series 238 products. Applicable Miami-Dade County Product Approvals (or TDI Approvals in Texas) should be used in conjunction with these instructions. Only experienced installers familiar with these or similar products should attempt to install these units. Refer to CGI Series 238 Design Guide for further information & details pertaining to these products.*

Technical support is available by contacting CGI at 305-593-6590 (local) or 1-800-442-9042



manufacturer of impact resistant windows and doors

[www.cgiwindows.com](http://www.cgiwindows.com)

## **OPENING PREPARATION AND WOOD BUCK INSTALLATION**

1. Make sure that masonry opening (or rough opening on stud construction) is made to within tolerance, level and plumb. Verify by measuring at each end and every 24" (vertically and horizontally). Make any corrections required to openings. Bucks must be set on a smooth and flat surface. Remove or chip away any concrete which protrudes from the face of the opening prior to setting bucks. Make sure ends of masonry opening are square and not rounded at corners. Chip concrete if necessary.
2. Select the size of Pressure Treated wood buck to be used (see *figure 1* or refer to Miami-Dade County Product Approvals for approved bucks) and decide how far from the face of the wall the bucks are going to be set. Most contractors like to set the wood bucks in about 2" from the exterior face of 8" concrete walls when installing windows.
3. Set wood bucks in a continuous heavy bed of professional grade sealant. Make sure sealant is applied at ends where bucks touch one another. Run a bead of sealant on exterior side of bucks between concrete and wood.
4. Make sure wood bucks are installed continuous and on all four sides of the opening. Wood bucks must touch one another at ends.
5. Install wood bucks level and plumb in all directions. Verify that opening is square. Do not follow the walls, as many times they tend to be leaning in or out.

## SERIES 238 WINDOWS - INSTALLATION INSTRUCTIONS

1. Check window opening for correct size.
2. Make sure wood bucks are of the correct size and type, properly bed in sealant and securely attached to structure (*figure 1*). Wood bucks should not be separated at corners. Verify that wood bucks are plumb, level and square.
3. If installing a Fixed Series 238 Window, remove the screws attaching the vent to the frame (see **Item 1** on *figure 2*), temporarily remove vent and save screws. If you have more than one window of the same size, make sure you label which vent belongs to which frame (they are not interchangeable). Also, mark the bottom edge of the vent to prevent from installing upside down.
4. Clean window flange and apply a generous amount of professional grade sealant / caulking material to flange at full perimeter. Make sure the sealant is compatible and will adhere to aluminum and wood.
5. Slightly open operable window (not required on fixed windows) and install window frame from outside on to wood bucks. If installing a Project-Out Series 238 Window or any window with a limited opening device, it may be necessary to disengage the operator arm or limit opening device to access all the screws on the frame.
6. Temporarily secure window frame using installation screws as selected from the Miami-Dade County Product Approvals (or TDI Approvals in Texas) for your specific application. Shim every installation screw snugly (shim space should not exceed 1/4"). Make sure operable windows operate correctly. Make sure that when closing an operable vent, window is not racked and closing unevenly. Make sure window is plumb, level and square. Tighten down all installation screws and verify that window still opens and closes correctly.  
**Caution: Any window frame, which is forced into an opening and racked or twisted, can cause glass breakage once the glazed vent is forced to adjust to the racked frame. This becomes extra important on Designer Fixed Windows.**
7. If installing mullion tubes, make sure tubes are properly attached to structure at each end with the supplied clips as per the Miami-Dade County Approvals (refer to *figures 3 & 4* for installation details).
8. Check window for leakage at corner frame joints. It may be necessary to reseal frame corners after installing. The factory applied sealant may get damaged during transport of the window due to racking.
9. Make sure there is no daylight between wood buck and window flange. If any exist or as a precautionary step, apply additional sealant at this joint.

10. If installing a Fixed Series 238 Window, re-attach the vent to the frame using the screws removed on step 3 above and cover screws with the plastic caps provided. Make sure screws are tightened to assure a watertight condition.

**Important: If the vent and frame do not appear to fit together, you may have installed the frame racked / twisted, or you may be using a vent from another window. Do not force the vent to fit or you may cause glass breakage.**

11. If installing an operable Series 238 window, check window for proper operation. Adjust keepers as required for proper locking. Lubricate moving hardware using silicone based lubricant.

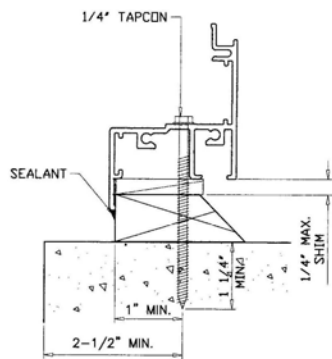
**INSTALLATION HINT:** If the window does not close properly and evenly, then re-check plumb ness, level and square ness.

### **RECOMMENDED INSTALLATION SCREWS:**

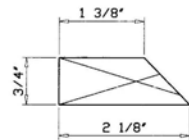
<b>Windows</b>	Into 1 X wood bucks:	1/4" x 3 1/4" Lg. Hex Tap-Con * (refer to Product Approval)
	Into 2 X wood bucks:	1/4" Hex head Tap-Con * (To penetrate 1 1/2" min. into wood).
	Into Mullions:	#12 x 1 1/4" Lg. Pan head S.M.S. Stainless Steel.
<b>Mullion Clips</b>	Into concrete:	1/4" x 1 3/4" Lg. Hex head Tap-Con. *

---

\* Concrete anchors must carry current Miami-Dade County Product Approval.  
\* Concrete anchors must carry current Miami-Dade County Product Approval.



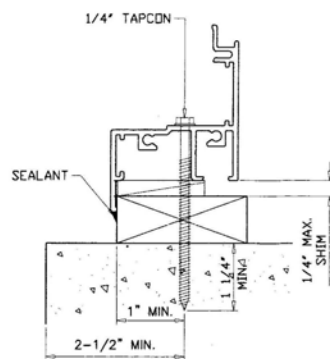
**INSTALLATION TYPE '1'**



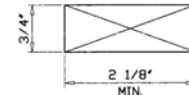
**WOOD BUCK TYPE '1'**

MATERIAL: PRESSURE TREATED

**TYPICAL INSTALLATION DETAIL  
ON ALL FOUR SIDES/USING WOOD**



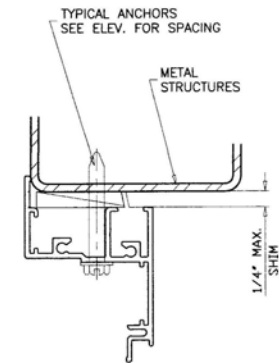
**INSTALLATION TYPE '2'**



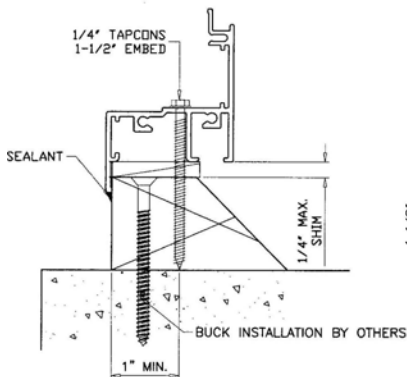
**WOOD BUCK TYPE '2'**

MATERIAL: PRESSURE TREATED

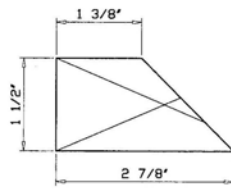
**TYPICAL INSTALLATION DETAIL  
ON ALL FOUR SIDES/USING WOOD**



**ATTACHMENT TO  
METAL STRUCTURES**



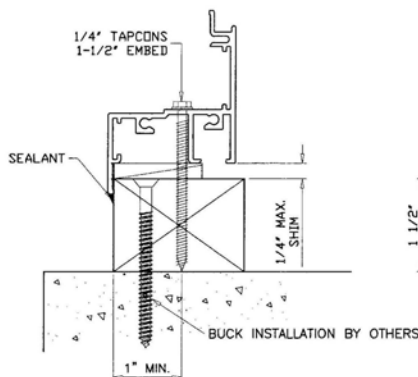
**INSTALLATION TYPE '3'**



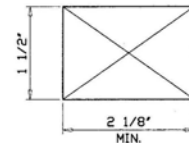
**WOOD BUCK TYPE '3'**

MATERIAL: PRESSURE TREATED

**TYPICAL INSTALLATION DETAIL  
ON ALL FOUR SIDES/USING WOOD**



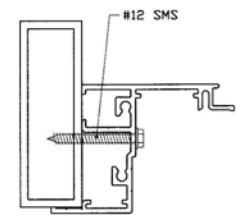
**INSTALLATION TYPE '4'**



**WOOD BUCK TYPE '4'**

MATERIAL: PRESSURE TREATED

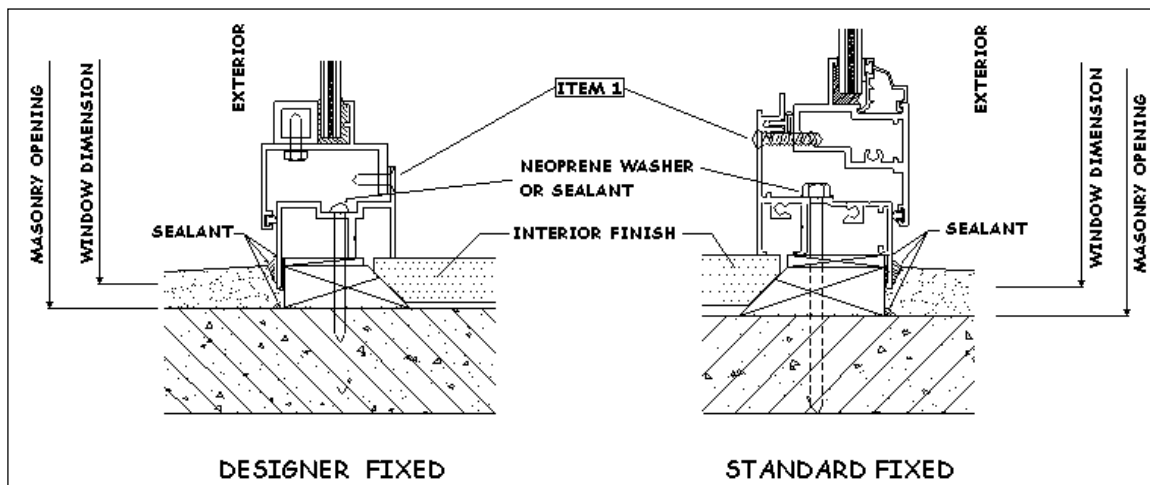
**TYPICAL INSTALLATION DETAIL  
ON ALL FOUR SIDES/USING WOOD**



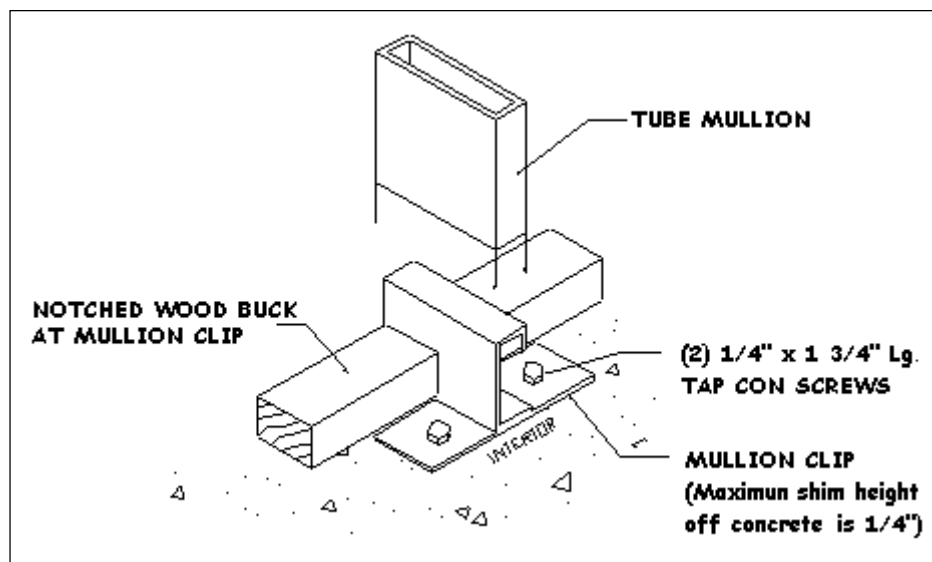
**ATTACHMENT TO  
APPROVED MULLIONS**

**Figure 1: Buck preparation and frame installation (standard details).**

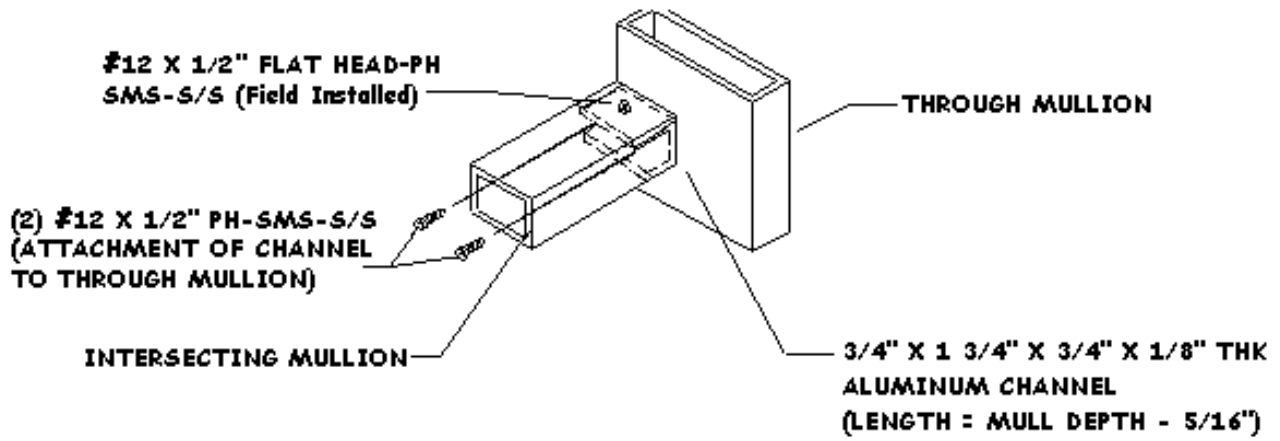




**Figure 2:** Fixed window attaching screws.



**Figure 3:** Mullion end anchorage detail.



**Figure 4:** Mullion to mullion anchorage detail.